

Module #1: The Basics

Introduction

In this course, you are going to learn a lot about the world around you and the universe that it is in. We will study things as familiar as the air around you and others as mysterious as radioactivity and distant galaxies. We will learn about the structure of the earth as well as its place in the solar system and the universe. The study of these topics and many others like them are all a part of what we call **physical science**.

In order to make sure that we are both starting on the “same page,” I need to discuss some basic concepts with you. It is quite possible that you have learned some (or all) of this before, but it is necessary that we cover the basics before we try and do anything in depth. Thus, even if some of the topics I cover sound familiar, please read this module thoroughly, so that you will not get lost in a later module. In fact, many of the subjects that I will cover in later modules are probably familiar to you on one level or another. After all, most students your age know something about air, the construction of our planet, weather, and astronomy. Nevertheless, I can almost guarantee you that you have not learned these subjects at the depth in which I will discuss them in this course. So, despite how much you might think you know on a given topic, please read the material I present to you carefully. I doubt that you will be disappointed.

If, on the other hand, all of this is completely new to you, don't worry about it. As long as you read the material carefully, perform the experiments thoroughly, and really *think* about what you learning, everything will be fine. Although this course might not be *easy* for you, there are very few things in life that are both *easy and worthwhile*. I promise you that if you *work* at learning this course, you will gain a great deal of knowledge, a solid sense of accomplishment, and a grand appreciation for the wonder of God's Creation!

Atoms and Molecules

In this course, I am going to illustrate as many concepts as possible with experiments. Hopefully, the “hands on” experience will help bring those concepts home better than any discussion could. In some cases, of course, this will not be possible, so we will have to make due with words and pictures. To start our discussion of atoms and molecules, I want you to perform the following experiment.

EXPERIMENT 1.1 Atoms and Molecules

Supplies:

A small glass, like a juice glass

Baking soda

Tap water

A 9-Volt battery (the kind that goes in a radio, smoke detector, or toy. **DO NOT** use an electrical outlet, as it will most likely kill you! A 1.5 Volt flashlight battery will not work.)

Two 9-inch pieces of insulated wire. The wire itself must be copper.

A pair of scissors

Some tape (preferably electrical tape, but cellophane or masking tape will work)

Introduction - Atoms and molecules make up everything that surrounds us. Individually, they are simply too small to see. However, you can distinguish between different kinds of atoms and different kinds of molecules by examining the substances that they make up, as well as how those substances change. In this experiment, we will observe molecules changing into atoms and atoms changing into molecules. By observing these changes, you will learn about the difference between atoms and molecules.

Procedure:

- A. Fill your small glass 3/4 full of tap water.
- B. Add a teaspoon of baking soda and stir vigorously.
- C. Use your scissors to strip about a quarter inch of insulation off both ends of each wire. The best way to do this is to put the wire in your scissors and squeeze the scissors gently. You should feel an increase in resistance as the scissors begin to touch the wire. Squeeze the scissors until you feel that resistance and then back off. Continue squeezing and backing off as you slowly turn the wire round and round.

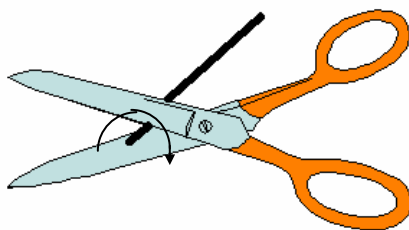

Be careful. You can cut yourself if you are not paying proper attention! You will eventually have a cut that goes through the insulation all the way around the wire. At that point, you can simply pull the insulation off. It will take some practice to get this right, but you *can* do it. Make sure that there is at least a quarter inch of bare wire sticking out of both ends of wire.

- D. Once you have stripped the insulation off both ends of each wire, connect the end of one wire to one of the two terminals on the battery. Do this by laying the wire over the terminal and then pressing it down. Secure it to the terminal with a piece of tape. It need not look pretty, but it needs to be solidly touching one terminal and not in contact with the other terminal.
- E. Repeat step D with the other wire and the other battery terminal. Now you have two wires attached to the battery, one at each terminal. Do not allow the bare ends of these wires to touch each other!
- F. Now immerse the wires in the baking soda/water solution that is in your small glass so that the bare end of each wire is completely submerged. It doesn't really matter how much of the insulated portion of the wire is immersed, just make sure that all of the bare end of each wire is fully submerged. In the end, your experiment should look something like this:

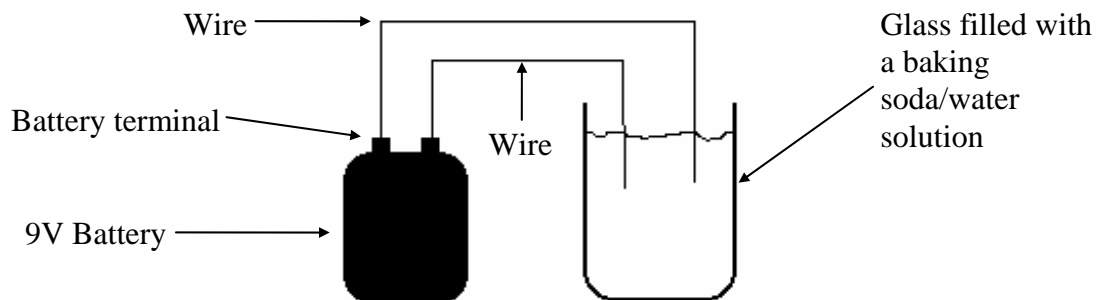

- G. Look at the bare ends of the wires as they are submerged in the baking soda/water solution. What do you see? Well, if you set everything up right, you should see bubbles coming from both ends. If you don't see bubbles, the most likely problem is that you do not have good contact between the wires and the battery terminals. Try pressing the ends of the wire hard against the terminals they are taped to. If you then see bubbles coming from the submerged ends of the wire, you know that electrical contact is your problem. If not, your battery might be dead. Try another one.
- H. Once you get things working, spend some time observing what's going on. Notice that bubbles are forming on *both* wires. That's an important point which should be written in your laboratory notebook.
- I. Allow the experiment to run for about ten minutes. After that time, pull the wires out of the solution and look at the bare ends. What do you see? Well, one of the wires should really look no different than when you started. What about the end of the other wire? It should now be a different color. What color is it? Write that color down in your notebook.
- J. If you really let the experiment run for 10 minutes, it's very possible that your solution became slightly colored. Write in your notebook whether or not that did happen and what color, if any, the solution became.
- K. Looking at the wire that changed color, trace it back to the battery and determine which terminal (positive or negative) it was attached to. Write that in your laboratory notebook as well.
- L. **Clean up:** Disconnect the wires from the battery, discard the solution, and wash the glass thoroughly. Put everything away.

Now, to understand what went on in the experiment, you need a little background information. Everything that you see around you is made up of tiny little units called **atoms**.

Atom - The smallest stable unit of matter in Creation

Atoms are so small that you cannot see them at all. They are so small, in fact, that roughly 100,000,000,000,000,000 atoms are contained in the head of a pin. If we can't see them, then how do we know that they exist? Well, lots of experiments have been done that can only be explained if you *assume* that atoms exist; thus, there is a lot of *indirect* evidence that atoms exist. All of this indirect evidence leads us to believe that atoms are, indeed, real.

When you stripped the insulation off the ends of each wire, you saw the familiar red-orange color of copper wire. Well, it turns out that copper is a type of atom. Thus, the copper that you observed in the wire was really just a bunch of copper atoms lumped together. You couldn't see the *individual* atoms, but when billions of billions of billions of them are put together, you can see the substance that they make. When you have billions of billions of billions of copper atoms, you get the flexible, electricity-conducting, red-orange metal called copper.

We currently know that there are about 109 basic kinds of atoms in Creation. This number increases as time goes on because, every once in a while, scientists will discover a new kind of atom. In a few years, then, the number of basic kinds of atoms in Creation will probably be a little larger. That's why I say "about" 109 different kinds of atoms in Creation.

If this were the end of the story, Creation would be pretty boring. After all, if everything that you see is made up of atoms, and if there are only about 109 different kinds of atoms in Creation, then there are only 109 different substances in Creation, right? Of course not! Although God used atoms as the basic building blocks of Creation, He designed those atoms to link together to form larger building blocks called **molecules**.

Molecule - Two or more atoms linked together to make a substance with unique properties

It turns out that the water that you used in your experiment is made up of molecules. Although molecules are bigger than atoms, you still cannot really see them. Thus, the water that you see is made up of billions of billions of billions of water molecules, just like the copper wire is made up of billions of billions of billions of atoms of copper. A water molecule is formed when an oxygen atom links together with two hydrogen atoms. When these atoms link together in a very specific way, the result is a water molecule.

Now we are ready to really discuss the results of the experiment. When you filled the glass with water, you were filling it with billions of billion of billions of water molecules. When you placed the wires (which were connected to the battery) into the water, the electricity from the battery began flowing through the water. When this happened, the energy from the electricity flow actually broke some of the water molecules down into hydrogen and oxygen, which began bubbling out of the water because hydrogen and oxygen are gasses!

This is an excellent illustration of atoms and molecules. Each water molecule is made of two hydrogen atoms and an oxygen atom linked together. When these atoms link together in that way, an odorless, colorless, tasteless liquid we call water is formed. When electricity is used to break the water molecules down, hydrogen and oxygen are formed. Hydrogen is an explosive gas with an acrid smell while oxygen is the gas that we breathe to stay alive. Think about that. Oxygen and hydrogen are each gasses with particular properties. When they link together, however, these individual properties are lost and a new substance is formed. If the links between these atoms are broken, then the atoms separate and go back to their original forms!

In the water portion of the experiment, you saw a molecule (water) breaking back down into its constituent atoms (hydrogen and oxygen). Well, when you pulled the wires out of the water in ten minutes, you saw that the wire connected to the positive terminal of the battery had turned a blueish-green color. In this case, the copper atoms in the wire interacted with water molecules and baking soda molecules, aided by the energy contained in the electricity. The result is a blue-green substance called copper hydroxycarbonate (hi drok' see car' buh nate). Copper hydroxycarbonate is formed when a copper atom links together oxygen atoms, carbon atoms, and hydrogen atoms. In this experiment, the hydrogen and oxygen atoms came from both the water and the baking soda, the carbon atoms came from the baking soda alone, and the copper atoms came from the wire. In this case, then, you observed atoms (copper) linking up with other atoms (oxygen, carbon, and hydrogen) to make a molecule (copper hydroxycarbonate).

Interestingly enough, copper hydroxycarbonate is the same substance that you see on many statues, such as the Statue of Liberty. You see, if a statue has copper on it and is exposed to weather, a process similar to the one that you observed turns the copper atoms in the statue into copper hydroxycarbonate. As a result, the statue turns green, just like one of the copper wires did in your experiment.

FIGURE 1.1
The Statue of Liberty

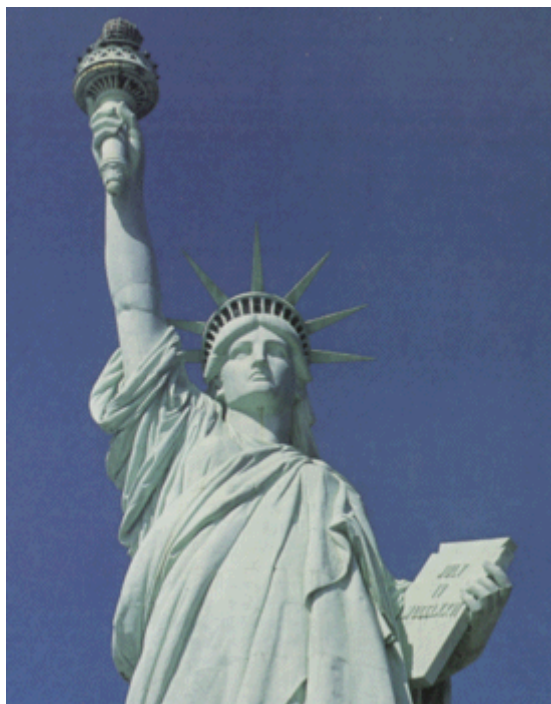

*Photo courtesy of the National
Libertarian Party*

The Statue of Liberty has turned green over the years because hydrogen, oxygen, and carbon atoms from various substances in the air have combined with the copper atoms in the statue to make copper hydroxycarbonate.

This is how we get all of the incredible substances that you see around you. Some substances (copper, aluminum, and some others) are simply billions of billions of billions of atoms that form the substance. Other substances that we see (water, salt, sugar, and many others) are made up of billions of billions of billions of molecules. Finally, many substances that we see (wood, cereal, plastics, and many others) are actually mixtures of several different substances, each of which is made up of either atoms or molecules. To reinforce this description of atoms and molecules, study Figure 1.2.

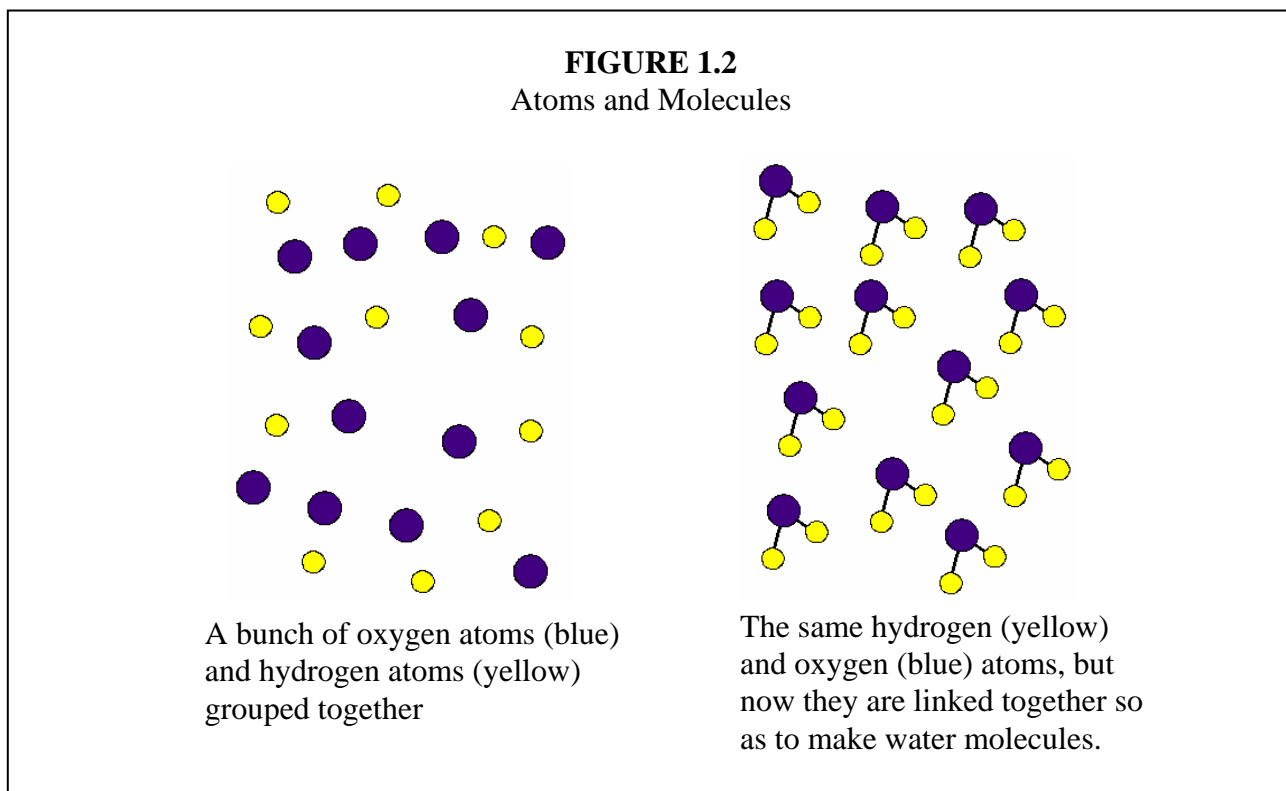

Okay, I am finally done discussing the experiment. Now that you know what the experiment shows, you can write a summary in your laboratory notebook. Write a brief description of what you did, followed by a discussion of what you learned. You will need to do each experiment in this way. Once you have done an experiment and read the discussion that relates to it, you then need to write a summary explaining what you did and what you learned. This will help you get the most from your laboratory exercises.

Now that I am done presenting the concept of atoms and molecules, you need to answer the following “on your own” problems in order to make sure that you understand what you have read. These kinds of problems will show up periodically, and you should answer them as soon as you come to them in your reading.

ON YOUR OWN

- 1.1 A molecule is broken down into its constituent atoms. Do these atoms have the same properties that the molecule had?
- 1.2 When salt is dissolved in water, it actually breaks down into two different substances. Is salt composed of atoms or molecules?

Before you go on to the next section, I want to dispel a myth that you might have heard. In many simplified science courses, students are told that scientists have actually seen atoms by using an instrument called a “scanning tunneling electron microscope.” Indeed, students are shown figures such as the one below and are told that the conical shapes you see in the picture are atoms.

FIGURE 1.3

A Scanning Tunneling Electron Microscope Image of the Surface of a Nickel Foil

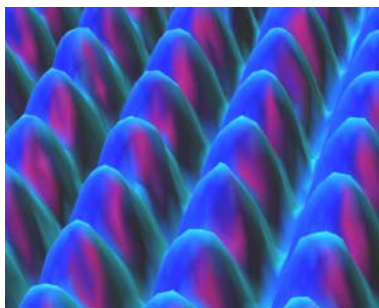

Photo courtesy of the IBM research division

Is this what nickel atoms really look like? Are you really seeing a picture of atoms here? Well, although it looks good, it is not really a picture of atoms. You see, a scanning tunneling electron microscope does not allow you to see things the way a regular microscope does. Instead, it passes a charged probe across the surface of an object and measures slight changes in electricity that flows through the probe. It then sends that data to a computer which uses a complicated set of mathematical equations from a theory called “quantum mechanics” to calculate what the surface of the object should look like. The computer then graphs the results of that calculation. That’s what is pictured in Figure 1.3.

So, what you are really seeing in Figure 1.3 is the result of a *calculation* which comes from a *theory* about how electricity flows under certain circumstances. Thus, *if* the theory is correct, and *if* the computer calculation is correct, *then* you are seeing atoms on the surface of the metal that was examined with the scanning tunneling electron microscope. Those are two big “ifs,” however. Never be fooled by someone who tells you that we have seen atoms. We have not. We have only seen the results of computer calculations that may or may not be right!

Measurement and Units

Let's suppose I'm making curtains for a friend's windows. I ask the person to measure the window and give me the dimensions so that I can make the curtains the right size. My friend tells me that his windows are 50 by 60, so that's how big I make the curtains. When I go over to his house, it turns out that my curtains are more than twice as big as his windows! My friend tells me that he's certain he measured the windows right, and I tell my friend that I'm certain I measured the curtains right. How can this be? The answer is quite simple. My friend measured the windows with a metric ruler. His measurements were in *centimeters*. I, on the other hand, used a yardstick and measured my curtains in *inches*. Our problem was not caused by one of us measuring incorrectly. Instead, our problem was the result of measuring with different **units**.

When we are making measurements, the units we use are just as important as the numbers that we get. If my friend had told me that his windows were 50 centimeters by 60 centimeters, there would have been no problem. I would have known exactly how big to make the curtains. Since he failed to do this, the numbers that he gave me (50 by 60) were essentially useless. In the end, then, scientists never simply report numbers; they always include units with those numbers, so that everyone knows exactly what those numbers mean. That will be the rule in this course. If you answer a question or a problem and do not list units with the numbers, your answer will be considered incorrect. In science, numbers mean nothing unless there are units attached to them.

Since scientists use units in all of their measurements, it is convenient to define a standard set of units that will be used by everyone. This system of standard units is called the **metric system**.

The Metric System

There are many different things that we need to measure when studying Creation. First, we must determine how much matter exists in the object that we want to study. We know that there is a lot more matter in a car than there is in a feather, since a car weighs significantly more than a feather. In order to study an object precisely, however, we need to know *exactly* how much matter is in the object. To accomplish this, we measure the object's **mass**. In the metric system, the unit for mass is the **gram**. If an object has a mass of 10 grams, we know that it has exactly 10 times the matter that is in an object whose mass is 1 gram. To give you an idea of the size of a gram, the average mass of a housefly is just about 1 gram. Based on this little fact, we can say that a gram is a rather small unit. Most of the things that we will measure will have masses of 10 to 10,000 grams. For example, when full, a twelve-ounce can of soda pop has a mass of about 375 grams.

Now that we know what the metric unit for mass is, we need to know a little bit more about the concept itself. Many people think that mass and weight are the same thing. This misconception arises because the more an object weighs, the more mass it has. Thus, people tend to think that mass and weight are equivalent. That's not true. Mass and weight are two

different things. Mass measures how much matter exists in an object. Weight, on the other hand, measures how hard a planet's gravity pulls on that object.

For example, if I were to get on my bathroom scale and weigh myself, I would find that I weigh 170 pounds. However, if I were to take that scale to the top of Mount Everest and weigh myself, I would find that I only weighed 167 pounds there. Does that mean I'm thinner on the top of Mount Everest than I am at home? Of course not. It means that on the top of Mount Everest, earth's gravity is not as strong as it is in my house. If I were to weigh myself on the moon, I would find that I only weigh 28 pounds. That's because the gravity on the moon is very weak.

On the other hand, if I were to measure my mass at home, I would find it to be 76,600 grams. If I were to measure my mass at the top of Mount Everest, it would still be 76,600 grams. Even on the moon, my mass would be 76,600 grams. That's the difference between mass and weight. Since weight is a measure of how hard gravity pulls, an object weighs different amounts depending on where that object is. Mass, on the other hand, is a measure of how much matter is in an object and does not depend on where that object is.

Unfortunately, there are many other unit systems in use today besides the metric system. In fact, the metric system is probably not the system with which you are most familiar. You are probably most familiar with the English system. The unit of pounds comes from the English system. Now, as I stated before, pounds are not a measure of mass; they are a measure of weight. The metric unit for weight is called the **Newton**. The English unit for mass is (believe it or not) called the **slug**. Although we will not use the slug often, it is important to understand what it means.

There is more to measurement than just grams, however. We might also want to measure how big an object is. For this, we must use the metric system's unit for distance, which is the **meter**. If you stretch out your left arm as far as it will go, the distance from your right shoulder to the tip of the fingers on your left hand is about 1 meter. The English unit for distance is the **foot**. What about inches, yards, and miles? We'll talk about those a little later.

We also need to be able to measure how much space an object occupies. This measurement is commonly called "volume" and is measured in the metric system with the unit of **liter**. The main unit for measuring volume in the English system is the gallon. To give you an idea of the size of a liter, it takes just under four liters to make a gallon.

Finally, we have to be able to measure the passage of time. When studying Creation, we will see that its contents have the ability to change. The shape, size, and chemical properties of certain substances change over time, so it is important to be able to measure time so that we can determine how quickly the changes take place. In both the English and metric systems, time is measured in **seconds**. Once again, we'll talk about minutes, hours, and days a little later.

Since it is very important for you to be able to recognize what units correspond to which measurements, Table 1.1 summarizes what you have just read. The letters in parentheses are the commonly used abbreviations for the units listed.

TABLE 1.1
Physical Quantities and Their Base Units

Physical Quantity	Base Metric Unit	Base English Unit
Mass	gram (g)	slug (sl)
Distance	meter (m)	foot (ft)
Volume	liter (L)	gallon (gal)
Time	second (s)	second (s)

Manipulating Units

Now, let's suppose I asked you to measure the width of your home's kitchen using the English system. What unit would you use? Most likely, you would express your measurement in feet. However, suppose instead I asked you to measure the length of a pencil. Would you still use the foot as your measurement unit? Probably not. Since you know the English system already, you would probably recognize that inches are also a unit for distance and, since a pencil is relatively small, you would use inches instead of feet. In the same way, if you were asked to measure the distance between two cities, you would probably express your measurement in terms of miles, not feet. This is why I used the term "Base English Unit" in the table above. Even though the English system's normal unit for distance is the foot, there are alternative units for length if you are trying to measure very short or very long distances. The same holds true for all English units. Time, for example, can be measured in seconds, minutes, hours, days, or years.

This concept exists in the metric system as well. There are alternative units for measuring small things as well as alternative units for measuring big things. These alternative units are called "prefix units," and, as you will soon see, prefix units are much easier to use and understand than the English units which you grew up with! The reason that prefix units are easy to use and understand is that they always have the same relationship to the base unit, regardless of what physical quantity you are interested in measuring. You will see how this works in a minute.

In order to use a prefix unit in the metric system, you simply add a prefix to the base unit. For example, in the metric system, the prefix "centi" means one hundredth, or 0.01. So, if I wanted to measure the length of a pencil in the metric system, I would probably express my measurement with the centimeter unit. Since a centimeter is one hundredth of a meter, it can be used to measure relatively small things. On the other hand, the prefix "kilo" means 1,000. So, if I want to measure the distance between two cities, I would probably use the kilometer. Since each kilometer is 1,000 times longer than the meter, it can be used to measure long things.

Now, the beauty of the metric system is that these prefixes mean the same thing *regardless of the physical quantity that you want to measure!* So, if I were measuring something with a very large mass (such as a car), I would probably use the kilogram unit. One kilogram is the same as 1,000 grams. In the same way, if I were measuring something that had a large volume, I might use the kiloliter, which would be 1,000 liters.

Compare this incredibly logical system of units to the chaotic English system. If you want to measure something short, you use the inch unit, which is equal to one twelfth of a foot. On the other hand, if you want to measure something with small volume, you might use the quart unit, which is equal to one fourth of a gallon. In the English system, every alternative unit has a different relationship to the base unit, and you must remember all of those crazy numbers. You have to remember that there are 12 inches in a foot, 3 feet in a yard, and 5280 feet in a mile while at the same time remembering that for volume there are 8 ounces in a cup, 2 cups in a pint, 2 pints in a quart, and 4 quarts in a gallon.

In the metric system, all you have to remember is what the prefix means. Since the “centi” prefix means one hundredth, then you know that 1 centimeter is one hundredth of a meter, 1 centiliter is one hundredth of a liter, and 1 centigram is one hundredth of a gram. Since the “kilo” prefix means 1,000, you know that there are 1,000 meters in a kilometer, 1,000 grams in a kilogram, and 1,000 liters in a kiloliter. Doesn’t that make a lot more sense?

Another advantage to the metric system is that there are many, many more prefix units than there are alternative units in the English system. Table 1.2 summarizes the most commonly used prefixes and their numerical meanings. The prefixes in boldface type are the ones that we will use over and over again. You will be expected to have those three prefixes and their meanings memorized. Once again, the commonly used abbreviations for these prefixes are listed in parentheses.

TABLE 1.2
Common Prefixes Used in the Metric System

PREFIX	NUMERICAL MEANING
micro ()	0.000001
milli (m)	0.001
centi (c)	0.01
deci (d)	0.1
deca (D)	10
hecta (H)	100
kilo (k)	1,000
Mega (M)	1,000,000

Remember that each of these prefixes, when added to a base unit, makes an alternative unit for measurement. So, if you wanted to measure the length of something small, the only unit you could use in the English system would be the inch. However, if you used the metric system, you would have all sorts of options for which unit to use. If you wanted to measure the length of someone’s foot, you could use the decimeter. Since the decimeter is one tenth of a meter, it

measures things that are only slightly smaller than a meter. On the other hand, if you wanted to measure the length of a sewing needle, you could use the centimeter, because a sewing needle is significantly smaller than a meter. If you wanted to measure the length of an insect's antenna, you might use the millimeter, since it is one thousandth of a meter, which is a *really* small unit.

So you see that the metric system is more logical and versatile than the English system. That is, in part, why scientists use it as their main system of units. The other reason that scientists use the metric system is that most countries in the world use it. With the exception of the United States and Great Britain, almost every other country in the world uses the metric system as its standard system of units. Since scientists in the United States frequently work with scientists from other countries around the world, it is necessary that American scientists use and understand the metric system.

Converting Between Units

Now that you understand what prefix units are and how they are used in the metric system, you must become familiar with converting between units within the metric system. In other words, if you measure the length of an object in centimeters, you should also be able to convert your answer to any other distance unit. For example, if I measure the length of a pencil in centimeters, I should be able to convert that length to millimeters, decimeters, meters, etc. Accomplishing this task is relatively simple as long as you remember a trick you can use when multiplying fractions. Suppose I asked you to complete the following problem:

$$\frac{7}{64} \times \frac{64}{13} =$$

There are two ways to figure out the answer. The first way would be to multiply the numerators and the denominators together and, once you had accomplished that, simplify the fraction. If you did it that way, it would look something like this:

$$\frac{7}{64} \times \frac{64}{13} = \frac{448}{832} = \frac{7}{13}$$

You could get the answer much more quickly, however, if you remember that when multiplying fractions, common factors in the numerator and the denominator cancel each other out. Thus, the 64 in the numerator cancels with the 64 in the denominator, and the only factors left are the 7 in the numerator and the 13 in the denominator. In this way, you reach the final answer in one less step:

$$\frac{7}{\cancel{64}} \times \frac{\cancel{64}}{13} = \frac{7}{13}$$

We will use the same idea in converting between units. Suppose I measure the length of a pencil to be 15.1 centimeters, but suppose the person who wants to know the length of the pencil would like me to tell him the answer in meters. How would I convert between

centimeters and meters? First, I would need to know the relationship between centimeters and meters. According to Table 1.2, “centi” means 0.01. So, 1 centimeter is the same thing as 0.01 meters. In mathematical form, we would say:

$$1 \text{ centimeter} = 0.01 \text{ meter}$$

Now that we know how centimeters and meters relate to one another, we can convert from one to another. First, we write down the measurement that we know:

$$15.1 \text{ centimeters}$$

We then realize that any number can be expressed as a fraction by putting it over the number one. So we can re-write our measurement as:

$$\frac{15.1 \text{ centimeters}}{1}$$

Now we can take that measurement and convert it into meters by multiplying it with the relationship we determined above. We have to do it the right way, however, so that the units work out properly. Here’s how we do it:

$$\frac{15.1 \text{ centimeters}}{1} \times \frac{0.01 \text{ meters}}{1 \text{ centimeter}} = 0.151 \text{ meters}$$

This tells us that 15.1 centimeters is the same as 0.151 meters. There are two reasons this conversion method, called the **factor-label method**, works. First, since 0.01 meters is the same as 1 centimeter, multiplying our measurement by 0.01 meters over 1 centimeter is the same as multiplying by one. Since nothing changes when we multiply by one, we haven’t altered the value of our measurement at all. Second, by putting the 1 centimeter in the denominator of the second fraction, we allow the centimeters unit to cancel (just like the 64 canceled in the previous example). Once the centimeters unit has canceled, the only thing left is meters, so we know that our measurement is now in meters.

This is how we will do all of our unit conversions. We will first write the measurement we know in fraction form by putting it over one. We will then find the relationship between the unit we have and the unit to which we want to convert. Next, we will use that relationship to make a fraction that, when multiplied by our first fraction, cancels out the unit we have and replaces it with the unit we want to have. You will see many examples of this method, so don’t worry if you are a little confused right now.

It may seem odd to you that words can be treated exactly the same as numbers. Measuring units, however, have just that property. Whenever a measurement is used in any mathematical equation, the units for that measurement must be included in the equation. Those units are then treated the same way numbers are treated.

We will be using the factor-label method for many other types of problems as well, so it is very, very important for you to become an expert at using it. Also, since we will be using it so often, we should start abbreviating things so that they will be easier to write down. We will use the abbreviations for the base units that have been listed in Table 1.1 along with the prefix abbreviations listed in Table 1.2. Thus, kilograms will be abbreviated “kg” while milliliters will be abbreviated “mL.”

Since the factor-label method is so important in our studies of physical science, let’s see how it works in another example:

EXAMPLE 1.1

A student measures the mass of a rock to be 14,351 grams. What is the rock’s mass in kilograms?

First, we use the definition of “kilo” to determine the relationship between grams and kilograms:

$$1 \text{ kg} = 1,000 \text{ g}$$

Then we put our measurement in fraction form:

$$\frac{14,351 \text{ g}}{1}$$

Then we multiply our measurement by a fraction that contains the relationship noted above, making sure to put the 1,000 g in the denominator so that the unit of grams will cancel out:

$$\frac{14,351 \text{ g}}{1} \times \frac{1 \text{ kg}}{1,000 \text{ g}} = 14.351 \text{ kg}$$

Thus, 14,351 grams is the same as 14.351 kilograms.

ON YOUR OWN

1.3 A student measures the mass of a book as 12,321 g. What is the book’s mass in kg?

1.4 If a glass contains 0.121 L of milk, what is the volume of milk in mL?

1.5 On a professional basketball court, the distance from the three point line to the basket is 640.08 cm. What is this distance in meters?

As you may have guessed, the factor-label method can also be used to convert *between* systems of units as well as within systems of units. Thus, if a measurement is done in the

English system, the factor-label method can be used to convert that measurement to the metric system, or vice-versa. In order to be able to do this, however, you must learn the relationships between metric and English units. Although these relationships, summarized in Table 1.3, are important, we will not use them very often, so you needn't memorize them. If you need them on a test, they will be given to you.

TABLE 1.3
Relationships Between English and Metric Units.

Measurement	English/Metric Relationship
Distance	1 inch = 2.54 cm
Mass	1 slug = 14.59 kg
Volume	1 gallon = 3.78 L

We can use this information in the factor-label method the same way we used the information in Table 1.2.

EXAMPLE 1.2

The length of a tabletop is measured to be 37.8 inches. How many cm is that?

To solve this problem, we first put the measurement in its fraction form:

$$\frac{37.8 \text{ in}}{1}$$

We then multiply this fraction by the conversion relationship so that the inches unit cancels :

$$\frac{37.8 \text{ in}}{1} \times \frac{2.54 \text{ cm}}{1 \text{ in}} = 96.012 \text{ cm}$$

So, a measurement of 37.8 inches is equivalent to 96.012 cm.

Give yourself a little more practice with the factor-label method by answering the following “on your own” problems:

ON YOUR OWN

1.6 A piece of yarn is 3 inches long. How many centimeters long is it?

1.7 How many slugs are there in 12 kg?

1.8 If an object occupies 3.2 gallons of space, how many liters of space does it occupy?

The important thing to remember about the conversion system you just learned is that it can be used on *any* system of measurement, whether you are familiar with it or not. To see what I mean, perform the following experiment.

EXPERIMENT 1.2 Cubits and Fingers

Supplies

- A long piece of string
- Scissors
- A large table top (like a kitchen table or a big desk)
- A person to help you
- Some cellophane tape
- A pencil

Introduction: In the Old Testament, a measurement unit for length called the **cubit** was used. You can find reference to it in Genesis 6:15, for example, where God is telling Noah the dimensions of the ark. Back then, a cubit was defined as the length from a man's elbow to the tip of his outstretched middle finger. There was also a smaller unit of length measurement called the finger. It was defined as the distance from the last knuckle on a man's index finger to the tip of his index finger. You should immediately see a drawback of that measuring system. After all, arm length and finger length changes from man to man. As a result, the cubit that one man used was different than the cubit another man used. The same can be said for the finger. Nowadays, we use precise definitions for our measuring units so that they are the same all over the world. No matter where you go, a meter is a meter. That's not the way it used to be! In this experiment, you will make your own measuring devices for the cubit and the finger, and then you will get some practice converting between these measurement units.

Procedure:

- Hold your arm so that the elbow is bent but the rest of the arm stretches out horizontally. Open your palm so that your fingers stretch out in the same direction. Have the person helping you hold the end of the string at your elbow.

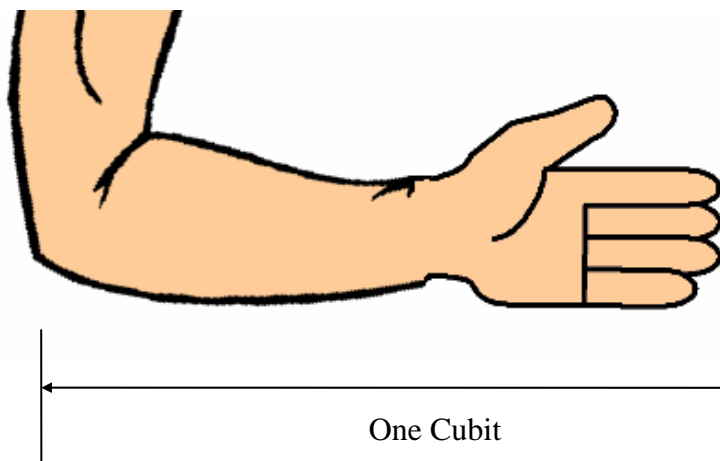

- B. Have your helper stretch the string tightly from your elbow to the tip of your middle finger, and then have him or her cut it so that you have a length of string which runs from your elbow to the tip of your middle finger. This is your cubit.
- C. Next, point your index finger straight out and have your helper stretch another piece of string so that it stretches from your last knuckle (the one nearest your fingernail) to the tip of your index finger. Have your helper cut the string so that it runs the length from your last knuckle to the tip of your index finger (not your finger nail). The string should be less than an inch long. This is your measurement for the “finger” unit.
- D. Take the string that represents your cubit and tape it down to the table top so that it is stretched out to its full length.
- E. Now, take the string that represents your finger and measure how many of those strings are in your cubit string. You can do this by simply starting at the beginning of your cubit string and stretching your finger string down next to it. Use your pencil to mark where the end of the finger string is on the cubit string. Now pick up the finger string and repeat the process, this time starting at the mark you made. Count the number of times that you did this, and that will tell you how many fingers are in a cubit. Most likely, this will not be a whole number. Try to estimate the fraction of the finger string it took to reach the end of the cubit string on your last measurement. In other words, if it took 18 finger strings to reach the end of your cubit string, but the cubit string only covered $\frac{1}{3}$ of the 18th finger string, then it really took 17.33 fingers to make a cubit.
- F. Record the number of finger strings (including the decimal) it took to reach the end of your cubit string. Now you know the number of fingers in one cubit.
- G. Unfasten your cubit string from the table top and measure the length of the table top in cubits. Do this the same way you measured the cubit before, laying the string end-to-end until you reach the end of the table top. Once again, if the end of the table top only covers a portion of the last cubit string in your measurement, try to estimate the fraction of a cubit that it covered. Record the length of the table top (including the decimal) in cubits.
- H. Now repeat that measurement, this time using your finger string instead.
- I. Do the same thing with the width of the table top, measuring it in both cubits and fingers.
- J. Now, take your measurement for the length of the table top in cubits and convert it into fingers using the number of fingers in a cubit you determined in step F. Compare your converted length in fingers to the number of fingers that you actually measured. If you did the conversion correctly, the answers should be similar. They won’t be exactly the same because of inaccuracies in your measurements. Nevertheless, they should be close. If they aren’t anywhere close to each other, then you probably did the conversion wrong. Check the example solution for this experiment that appears after the answers to the “on your own” problems. This should tell you how to do the conversion.
- K. Do the same thing for your measurement of table width; take your measured width in cubits and convert it to fingers. Then, compare your answer to the measured length in fingers to check the validity of your conversion. Once again, the numbers should be close.

Do you see why the factor-label method is so powerful? Even if you are not familiar with the unit system with which you are working, you can still convert between units as long as you have a conversion relationship.

Before we leave this section, there is one more metric unit I need to bring up. When we measure temperature, we usually use the **Celsius** temperature scale. Sometimes called the “centigrade” temperature scale, this temperature scale fits the metric system better than the Fahrenheit scale, with which you are probably more familiar. When we measure temperature on this scale, we list the unit as “degrees Celsius.” This unit does not have prefixes or anything, degrees Celsius is the only way to use the unit. The reason we tend to use this temperature scale instead of the Fahrenheit one is because this scale is based on factors of ten. On this temperature scale, water freezes at 0.00 degrees Celsius and boils at 100.0 degrees Celsius. This seems to fit right in to the metric system, which is also based on powers of ten. So, when I talk about temperature in this course, I will always use the degrees Celsius scale.

Concentration

In the past few sections, we discussed the units used to measure mass, length, and volume. Although these are very important things to measure, there is one other quantity with which you must be very familiar: **concentration**.

Concentration - The quantity of a substance within a certain volume of space

To get an idea of what concentration means, perform the following experiment.

EXPERIMENT 1.3

Concentration

Supplies:

Vinegar

6 TUMS tablets (You can use another antacid tablet, but it must have calcium carbonate as its active ingredient.)

Water

Measuring cups

3 large glasses (They each must be able to hold at least 2 cups of liquid.)

A spoon

Introduction - Vinegar is a weak acid, a kind of substance you will learn a lot more about when you take chemistry. TUMS are antacid tablets, designed to neutralize acid. Thus, when TUMS are added to vinegar, a chemical reaction occurs. The TUMS tablet disappears as it neutralizes the vinegar. While this happens, gas (carbon dioxide) bubbles off of the tablet.

Procedure

- A. Arrange your three glasses on a table or counter top. Put 1 cup of vinegar in the first glass, one-half of a cup of vinegar in the second glass, and one-fourth of a cup in the third.
- B. Place a TUMS tablet in each glass.
- C. Observe what's going on in each glass. Note in your laboratory notebook any differences that you see between what's going on in each glass. If you don't see any differences, note that as well.
- D. After you have finished observing the experiment, pour out the contents of each glass and rinse the glasses thoroughly.
- E. Dry the glasses and set them back on the counter or table top.
- F. Put 1 cup of vinegar in the first glass, one-half of a cup of vinegar in the second glass, and one-fourth of a cup in the third.
- G. Pour one cup of water in the first glass, one and one-half of a cup of water in the second glass, and one and three-quarters of a cup of water in the third glass, so that each glass has a total of 2 cups of liquid in it.
- H. Stir the contents of each glass thoroughly.
- I. Now place a single TUMS tablet in each glass.
- J. Observe what's going on in each glass. Record in your lab notebook what you see. Note the differences between what's going on in each glass.

What did you see when you observed the three glasses? Well, the first time, there really should have been little difference between what was happening in the three glasses. The antacid tablet in each of the three glasses should have bubbled and disappeared at roughly the same speed and in roughly the same fashion in each of the three glasses. The reason the tablet was bubbling and disappearing, of course, was that the chemical in the tablet was trying to neutralize the acid in the vinegar. The only difference between the glasses in the first part of the experiment was the total amount of vinegar present. Thus, it would take *less* of the tablet to neutralize the vinegar in the third glass than in the second or first glass. Nevertheless, while the acid in the vinegar was still present, the action in each of the glasses should have been essentially the same.

In the second part of the experiment, things were much different. In the first glass, you should have seen the TUMS tablet bubbling and disappearing slower than what you saw in the first part of the experiment. In the second glass, the tablet should have been bubbling and disappearing at a much slower rate than that of the tablet in the first glass. If you could see the tablet in the third glass bubbling and disappearing at all, it should have been extremely slow.

Why the differences between the three glasses in this part of the experiment? Each of them had TUMS and vinegar in them. Why did the tablet in the second glass disappear more slowly than the one in the first glass? Why did the tablet in the third glass disappear even more slowly or not at all? The answer: concentration. You see, each glass had vinegar in it, but the second glass had half as much vinegar as the first glass. In the first part of the experiment, there was half as much vinegar in the first glass, but there was also half as much volume. Thus, the concentration (how much exists in a *given volume*) of vinegar in the second glass was the same

as that in the first glass. In the second part of the experiment, however, there was half as much vinegar *in the same amount of volume* as the first glass. Since there was half as much vinegar in the same volume, the concentration of vinegar was half as much. As a result, the neutralization of acid by the TUMS went much more slowly.

In the third glass, the concentration of vinegar was so small that the TUMS tablet seemed to not disappear at all. So, this experiment shows us that the way chemicals behave depends on their concentration. When the concentration of vinegar is large, the neutralization of the acid in vinegar by a TUMS tablet is rather quick. When the concentration of vinegar is low, however, that same process proceeds slowly or not at all. This is perhaps the single most important thing that you can learn about chemicals. At certain concentrations, chemicals behave in one way. At other concentrations, those same chemicals behave in a completely different way.

Consider, for example, vitamins. There are certain vitamins, often called “fat soluble vitamins,” that your body never really gets rid of. These vitamins (vitamins A, D, E, and K) get stored in your body’s fat reserves if your body has more than it needs. As time goes on, those vitamins build up. If they get too concentrated, they can actually become *toxic* to the human body! Think about that for a moment. Vitamins, which are very good for you, can become toxic to you if they reach high concentrations. It is possible, in fact, to die as a result of taking *too many* vitamins!

Now don’t get paranoid about this! If you take one or two times the recommended daily allowance of vitamins A, D, E, and K, then they will never reach toxic concentrations in your body. Only if you take several times the recommended daily allowance of these vitamins do you risk them building up to toxic concentrations. The point, however, should not be lost. The behavior of chemicals depends on their concentration. Certain chemicals are good for you at one concentration and toxic for you at another. In the same way, chemicals that we call poisons are not necessarily bad for you at low enough concentrations!

This discussion has relevance to many issues in modern society. Consider, for example, the cigarette smoking debate that is raging in this country. For years, scientists have been able to directly link cigarette smoking to cancer. Scientific study after scientific study shows that smoking cigarettes dramatically increases your chance of getting lung cancer.

As the link between cigarette smoking and lung cancer became very clear, people began wondering about the effect of breathing someone else’s smoke. After all, consider the person who does not smoke but has a friend who does. This person spends a great deal of time with his friend and, any time that his friend smokes, he ends up inhaling the smoke as well. Scientists have called this phenomenon “second-hand smoke.” Can this person, who is continually inhaling second-hand smoke, be at risk for contracting cancer? Well, many studies have been done to answer this question, and the answer is surprising. The studies indicate that *if* inhaling second hand smoke increases a person’s likelihood of getting cancer, then the increased risk is very, very small. In fact, even in experiments where non-smokers who *lived with* smokers were studied, the increased risk for cancer caused by second-hand smoke was extremely small.

How can this be? If smoking significantly increases your risk of contracting lung cancer, why can't we see a similar link between second-hand smoke and lung cancer? The answer once again is concentration. When a smoker inhales cigarette smoke, the toxins in the smoke are very concentrated. When the smoke leaves either the cigarette or the smoker's mouth, it quickly spreads out into the surrounding air. This reduces the toxin concentrations significantly, in turn reducing the damage to anyone who inhales the smoke second-hand. As a result, second-hand smoke is not nearly as toxic as smoke that is inhaled by the smoker.

Of course, this in no way is an excuse for smokers who want to smoke around non-smokers. Even if a person's increased risk of lung cancer due to second-hand smoke is tiny (if it exists at all), it is simply unpleasant for non-smokers to breathe in smoke coming from a cigarette. Thus, you should never feel bad about asking a smoker to put out his or her cigarette! In fact, you are doing the smoker a favor, since science has conclusively shown a direct link between smoking and lung cancer!

The information contained in the last four paragraphs might have surprised you. If you follow modern politics at all, you might have heard people claim that second-hand smoke causes cancer. Unfortunately, it seems that people can claim almost anything these days and rarely get challenged by the major media outlets. It turns out that there have been *many* studies done on second-hand smoke, and the data simply say that there is little to no increase in risk of contracting lung cancer, even for someone who inhales second-hand smoke on a regular basis. If you are interested in looking into this controversy a little more, you might read *For Your Own Good: The Anti-Smoking Crusade and the Tyranny of Public Health* by Jacob Sullum (The Free Press, 1998).

ON YOUR OWN

1.9 Muratic acid is sold in hardware stores for use in cleaning. Pool owners, for example, use it to clean hard water stains and algae stains from their pools. Its active ingredient is hydrochloric acid. *The Works* is a toilet bowl cleaner whose active ingredient is also hydrochloric acid. There are approximately 350 grams of hydrochloric acid in a liter of muratic acid, and there are approximately 30 grams of hydrochloric acid in a liter of *The Works*. Why is muratic acid a more powerful cleaner than *The Works*?

1.10 Sodium is a necessary part of a healthy diet. If a person does not ingest enough sodium every day, that person will die. Nevertheless, most people try to limit their sodium intake by eating a low-salt diet. Why should you limit your sodium intake, even though it is a necessary part of body chemistry?

Now that you are done with the first module of this course, solve the study guide so that you will be reminded of the important concepts and skills in this chapter. Then you can take the test. The study guide is a very good indicator of what information you will be responsible for on the test.

ANSWERS TO THE ON YOUR OWN PROBLEMS

1.1 The atoms do not have the same properties as the molecule. When atoms join to make a molecule, their individual properties disappear and the molecule takes on its own, unique properties. When the molecule is broken down into its atoms, the atoms regain their individual properties.

1.2 Salt is made up of molecules. Since atoms are the smallest unit of matter in Creation, if salt can be broken into smaller parts, it must be made of atoms linked together. Thus, it is made of molecules.

1.3 We need to do this conversion the way the example showed us. First, we convert the number to a fractional form:

$$\frac{12,321 \text{ g}}{1}$$

Next, since we want to convert from grams to kg, we need to remember that since “kilo” means “1,000”, one kilogram is the same thing as 1,000 grams. Thus:

$$1 \text{ kg} = 1,000 \text{ g}$$

That’s our conversion relationship. Since we want to end up with kg in the end, then we must multiply the measurement by a fraction that has grams on the bottom (to cancel the gram unit that is there) and kg on the top (so that kg is the unit we are left with). Remember, the numbers next to the units in the relationship above go with the units. Thus, since “g” goes on the bottom of the fraction, so does “1,000.” Since “kg” goes on the top, so does “1.”

$$\frac{12,321 \text{ g}}{1} \times \frac{1 \text{ kg}}{1,000 \text{ g}} = 12.321 \text{ kg}$$

Thus, 12,321 g is the same as 12.321 kg.

1.4 We solve this the same way that we solved problem 1.3. First, we convert the number to a fractional form:

$$\frac{0.121 \text{ L}}{1}$$

Next, since we want to convert from liters to mL, we need to remember that “milli” means “0.001.” So, one milliliter is the same thing as 0.001 liters. Thus:

$$1 \text{ mL} = 0.001 \text{ L}$$

That's our conversion relationship. Since we want to end up with mL, we must multiply the measurement by a fraction that has liters on the bottom (to cancel the liter unit that is there) and mL on the top (so that mL is the unit we are left with):

$$\frac{0.121 \text{ L}}{1} \times \frac{1 \text{ mL}}{0.001 \text{ L}} = 121 \text{ mL}$$

Thus, 0.121 L is the same as 121 mL.

1.5 First, we convert the number to a fractional form:

$$\frac{640.08 \text{ cm}}{1}$$

Next, since we want to convert from centimeters to meters, we need to remember that "centi" means "0.01." So, one centimeter is the same thing as 0.01 meters. Thus:

$$1 \text{ cm} = 0.01 \text{ m}$$

That's our conversion relationship. Since we want to end up with meters in the end, then we must multiply the measurement by a fraction that has centimeters on the bottom (to cancel the cm unit that is there) and meters on the top (so that m is the unit we are left with):

$$\frac{640.08 \text{ cm}}{1} \times \frac{0.01 \text{ m}}{1 \text{ cm}} = 6.4008 \text{ m}$$

The three-point line is 6.4008 m from the basket.

1.6 We use the same procedure that we used in the previous three problems. Thus, I am going to reduce the length of the explanation.

$$\frac{3 \text{ in}}{1} \times \frac{2.54 \text{ cm}}{1 \text{ in}} = 7.62 \text{ cm}$$

The yarn is 7.62 cm long.

$$1.7 \quad \frac{12 \text{ kg}}{1} \times \frac{1 \text{ slug}}{14.59 \text{ kg}} = 0.822 \text{ slugs}$$

There are 0.822 slugs in 12 kg. Note that I rounded the answer. The real answer was "0.822481151," but there are simply too many digits in that number. When you take chemistry, you will learn about significant figures, a concept that tells you where to round numbers off. For right now, don't worry about it. If you rounded at a different spot than I did, that's fine.

$$1.8 \quad \frac{3.2 \text{ gal}}{1} \times \frac{3.78 \text{ L}}{1 \text{ gal}} = 12.096 \text{ L}$$

The object has a volume of 12.096 L.

1.9 Muratic acid is the more powerful cleaner because the active ingredient is more concentrated. In the same amount of volume, muratic acid has more than 10 times as much active ingredient. Since the active ingredient is more concentrated, it will clean better.

10.10 Sodium is necessary for the body at a certain concentration. If you eat too much sodium, then you raise the concentration too much. In the same way, if you eat too little sodium, you lower its concentration too much. Either way, your body suffers. Thus, you need to keep the sodium concentration in your body at the right level. Too little sodium intake will reduce the sodium concentration to critical levels, while too much sodium intake will raise it to toxic levels.

SAMPLE RESULTS FOR THE EXPERIMENT

Number of fingers in a cubit: 18.33

Measured length of the table: 2.5 cubits
45.25 fingers

Measured width of the table: 1.67 cubits
31 fingers

Conversions:

Length of table:

$$\frac{2.5 \text{ cubits}}{1} \times \frac{18.33 \text{ fingers}}{1 \text{ cubit}} = 45.825 \text{ fingers} \quad (\text{a little longer than but close to the measured value of 45.25 fingers})$$

Width of the table:

$$\frac{1.67 \text{ cubits}}{1} \times \frac{18.33 \text{ fingers}}{1 \text{ cubit}} = 30.611 \text{ fingers} \quad (\text{a little shorter than but close to the measured value of 31 fingers})$$

Notice that even though the converted lengths in fingers are not equal to the measured values, they are close. Your answers could be farther off, but they should be within 2.5 fingers.

STUDY GUIDE FOR MODULE #1

1. Write out the definitions for the following terms:
 - a. Atom
 - b. Molecule
 - c. Concentration
2. Fifty grams of a carbon disulfide can be broken down into 42.1 grams of sulfur and 7.9 grams of carbon. Is carbon disulfide made up of atoms or molecules?
3. If you put iron near a magnet, the iron will be attracted to the magnet. Rust is made up of molecules which contain iron atoms, oxygen atoms, and hydrogen atoms. Rust is not attracted to a magnet. If rust contains iron atoms, and iron is attracted to a magnet, why isn't rust attracted to a magnet?
4. A statue is made out of copper and displayed outside. After many years, what color will the statue be?
5. Have scientists actually seen atoms?
6. Give the numerical meaning for the prefixes centi, milli, and kilo.
7. If you wanted to measure an object's mass, what metric unit would you use? What English unit would you use?
8. If you wanted to measure an object's volume, what metric unit would you use? What English unit would you use?
9. If you wanted to measure an object's length, what metric unit would you use? What English unit would you use?
10. How many centimeters are in 1.3 meters?
11. If a person has a mass of 75 kg, what is his or her mass in grams?
12. How many liters of milk are in 0.5 gallons of milk? (1 gal = 3.78 L)
13. A meterstick is 100 centimeters long. How long is it in inches? (1 in = 2.54 cm)
14. Ozone is a poisonous gas that can build up in the air in dense cities. Thus, there are many environmental initiatives to lower the amount of ozone in the air. One way you can make ozone, however, is by baking bread. The nice smell that you associate with baking bread is actually due, in part, to ozone. If ozone is poisonous, why is baking bread not considered a dangerous activity?